

SIGHT LEVEL INDICATOR - SLI

A NEW COST EFFECTIVE SOLUTION FOR LEVEL INDICATION & SENSING IN HYDRAULIC OIL TANKS

Mechanical sight level Indicator is the best - known device for a low cost, still effective and convenient way for monitoring and sensing of liquid level in various process applications.

CONSTRUCTION AND OPERATION

The tough, transparent, acrylic cage of the level indicator assembly provides easy and effective visibility of the liquid level inside the tank through the guide tube with a pointer which moves inside the cage, indicating a continuous change in the rise or fall of liquid level.

Further provision is also made to mount the filler breather assembly to the same mounting flange of the indicator. Still further, to obtain single or two level switching output, suitable reed proximity switches or inductive proximity switches are clamped to the side of the cage with necessary brackets, also suitable to adjust the levels for sensing to the convenience of the operator at site in order to take out the signal from the sensor, depending upon the required level of the liquid for various switching operations like alarm, pump operation, solenoid operation, PLC input etc.,

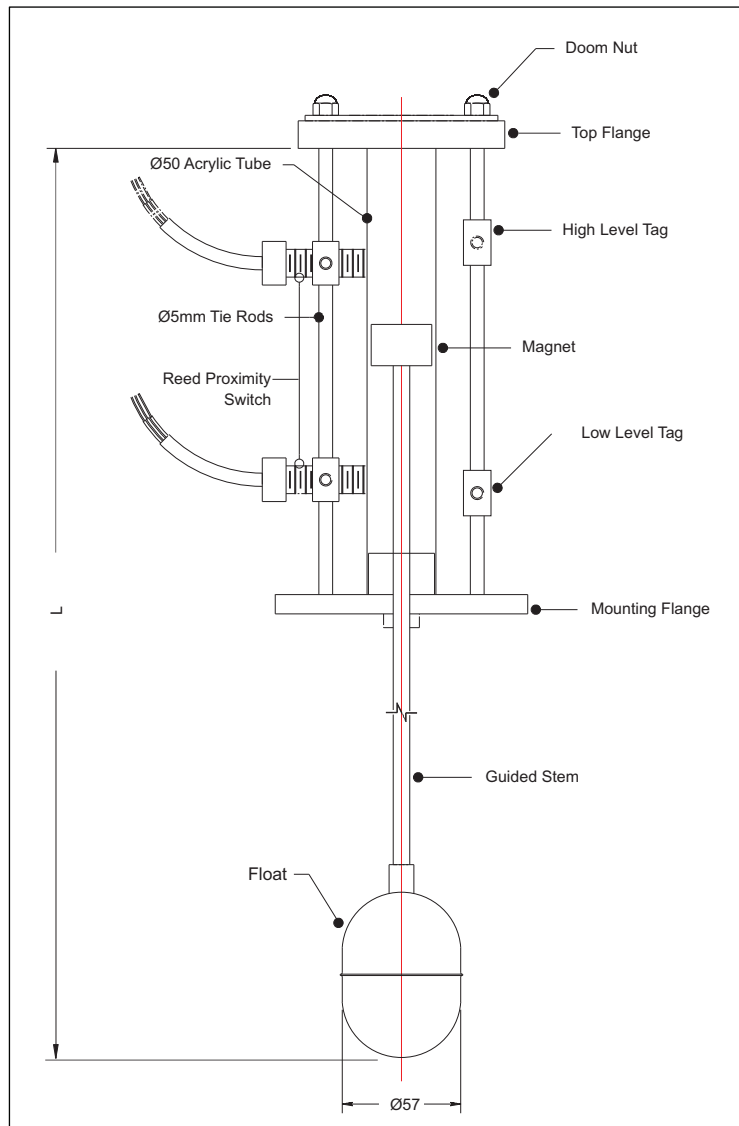

ORDERING INFORMATION FOR SIGHT LEVEL INDICATOR

SPECIFY PART NO. → S L I **1** **2** **3** **4**
 S L I

EXAMPLE → S L I

1 FLANGE

1. Ø 85 x 85 Square flange 105 PCD
2. Ø 75 x 65 PCD
3. Ø 95 x 55 Rectangular
4. With Breather Assembly
- O Others

1 **2** **3** **4**

2 FLOAT SIZE X MOC

1. Ø 45 x SS304
2. Ø 57 x SS304
3. Ø 89 x SS304
4. Others

3 SWITCHING CONTACT TYPE

- N Not Applicable
1. Reed proximity for SPST Switching
 2. Reed Proximity for SPDT Switching
 3. Inductive Proximity Sensor
 - O Others

4 ADDITIONAL ACCESSORIES

- N Not Applicable
1. Temperature Sensor PT100 type
 2. Temperature Sensor + Indicator
 3. M12 Pin type cable for Inductive Proximity (Optional)
 - O Others

TYPICAL INSTALLATION FOR SIGHT LEVEL INDICATOR

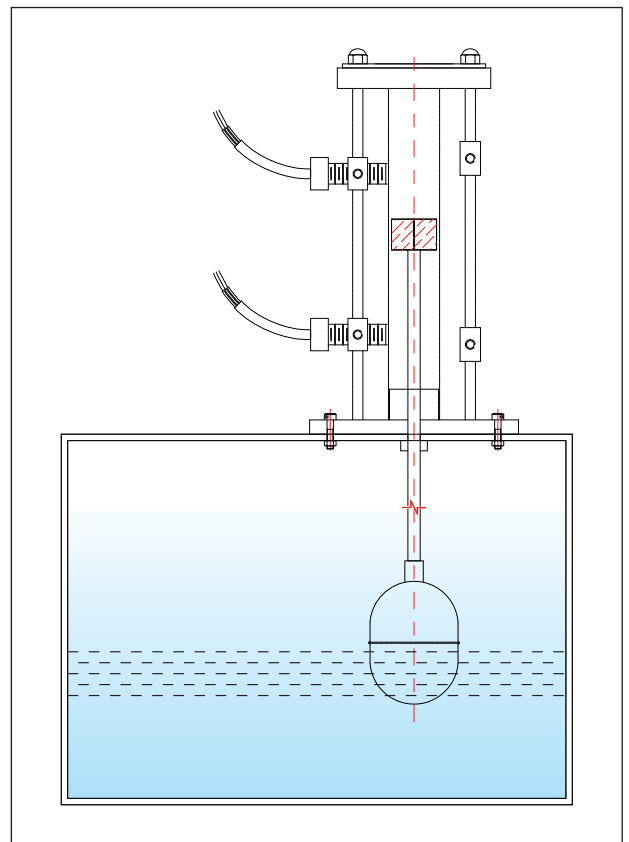

ADDITIONAL ACCESSORIES



Inductive proximity sensor with cable



Temperature Indicator with PT100 sensor



Sight Level Indicator with breather assembly

APPLICATION

Visual Indication in Hydraulic Power Packs, Hydraulic Oil Tanks where continuous maintenance is required etc.

ORDERING INFORMATION : Please specify part No., along with Guided Stem Length (Including Float Length) (L).

Note: All dimensions in MM, unless otherwise specified.

SHRIDHAN AUTOMATION PVT. LTD.,

#B-54, KSSIDC Industrial Estate, Kumbalagodu,
 Mysore Road, Bengaluru - 560074

Ph. : 080 - 28437847 / 28437848 ; Fax : 080 - 28437849

Email : info@shridhan.com ; Website : www.shridhan.com