

## VERTICAL MOUNTING TYPE MAGNETIC FLOAT LEVEL SWITCHES - VFS

It is an established and reliable technique in industry for single / multiple liquid level sensing and control in open or pressurized vessels. It offers trouble free service in conductive / non-conductive liquids under widely varying temperatures, pressures, liquid viscosity and corrosive conditions. Besides, it provides high repeatability and effects of shocks / vibrations are minimal.

### CONSTRUCTION & OPERATION

Magnetic reed switch being the sensing element, the float switch operates on a simple principle. A float encircling a fixed stationary stem is equipped with powerful permanent magnets. As the float rises or lowers with liquid level the magnetic field generated by the magnet that is present within the float actuates a hermetically sealed reed switch mounted inside the stem. This in turn makes or breaks the contact of the reed switch. **(Refer fig.01)**

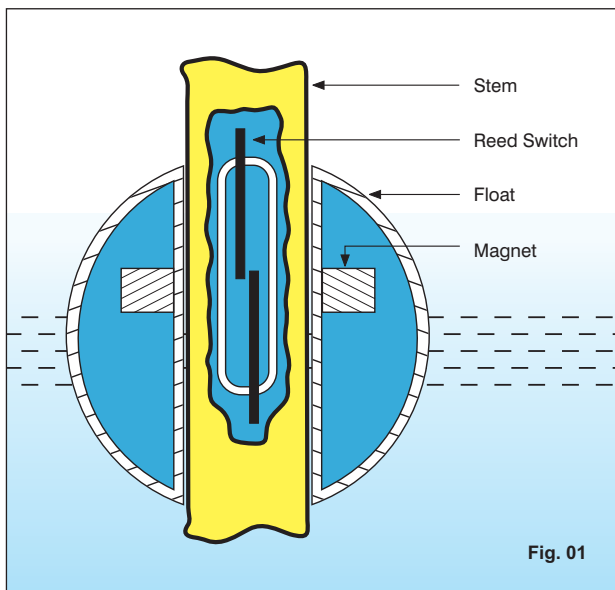

The reed switches used, are available in SPST & SPDT type. **(Refer fig.02)**

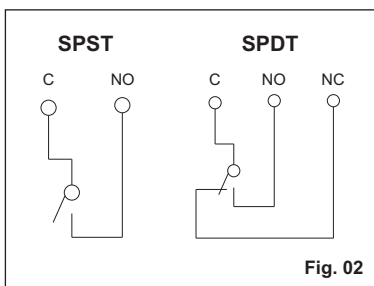

**SPST** - Normally open contact (NO)  
(Single pole single through)

**SPDT** - Changeover contact (C/O)  
(Single pole double through)



### Typical Level Switch Construction

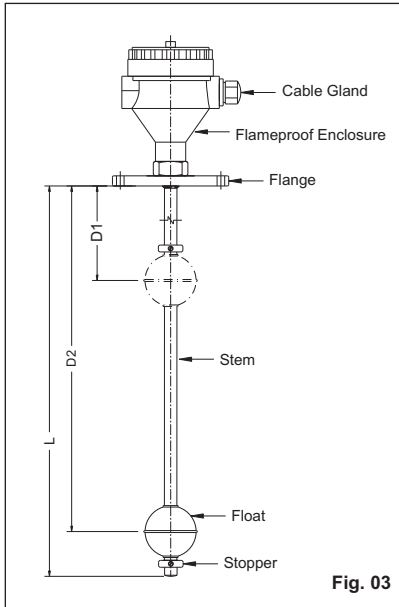
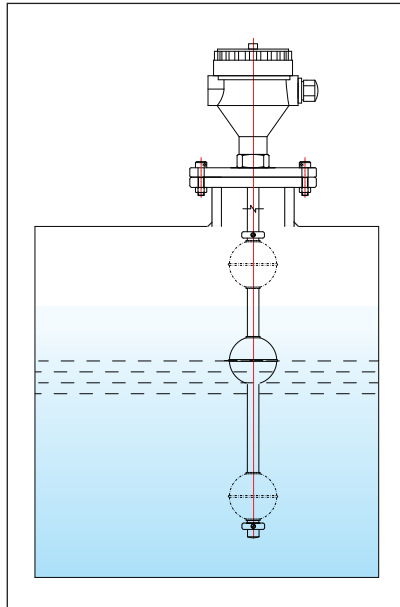
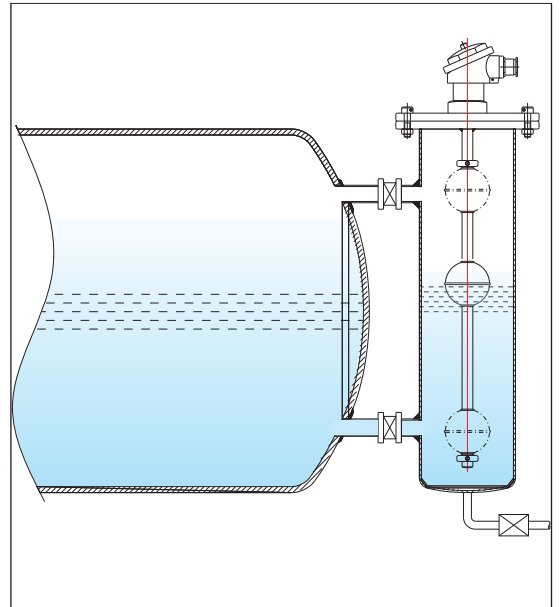

Fig. 03

### Mounting Insertion for Tanks



### External Cage Mounting



## SPECIFICATIONS

Enclosure	: Cast Al, W-proof to IP 66 / Ex-proof to Gr. IIA & IIB / DIN Polyamide connector
Conduit Connection	: Brass, 3/4" ET / 1/2" NPT
Guided Stem MOC	: SS316 / SS304 / Brass
Float MOC x Size	: SS316 x Ø22, Ø28, Ø30, Ø40, Ø52, Ø89 PU foam x Ø22, Ø25, Ø35
Stem OD	: Ø8, Ø12.7 in SS316 / SS304 / Brass
Operating Temperature	: SS316 - Ø52, Ø40 Upto 150°C, Ø22, Ø28, Ø30 Upto 100°C PU foam - Ø22, Ø25, Ø35 Upto 60°C
Operating pressure max.	: SS316 - Ø52, Ø40 Upto 20Kg / cm <sup>2</sup> , Ø22, Ø28, Ø30 Upto 8Kg / cm <sup>2</sup> PU foam - Ø22, Ø25, Ø35 - Atmospheric
Min. specific gravity	: 0.7
No. of floats	: Single / Multiple (Max.4) (More available on request)
Process connections	: Flanged / Threaded / Triclover Flange
Preset levels	: 1 to 4 (Factory set) (More available on request)
Switch type	: Glass encapsulated hermetically sealed reed contacts
Switching capacity	: 15VA (NO) / 100VA (NO) or 3VA (1C/O) / 50VA (1C/O)
Differential	: Fixed (10 ± 2mm)
Accuracy / Repeatability	: ± 2mm / ± 1mm
Load	: Resistive / Inductive
Insulation	: 100 Mega-Ohms at 500 VDC
Special Features	: Intrinsically safe to Ex ib Gr IIA-IIB

### Arc Suppression - Contact Protection Measures For Reed Switches

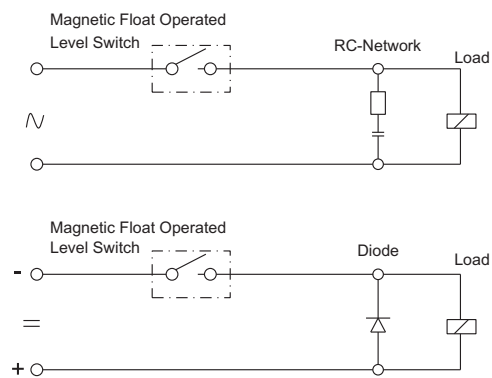

Fig. 04

### Level Switch With Automatic Level Controller (Provided as optional for specific applications)

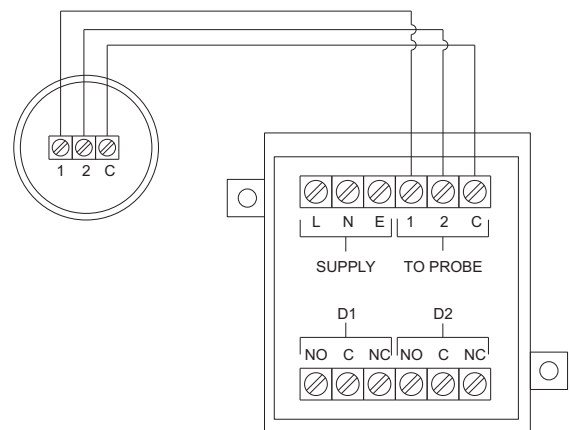

Fig. 05

# ORDERING INFORMATION FOR VERTICAL MOUNTING TYPE FLOAT SWITCHES

SPECIFY PART NO. → VFS **1** **2** **3** **4** **5**      Example : VFS **B** **A** **1** **S1** **1**

VFS

## 1 TERMINAL TYPE

- B : DIN Polyamide
- C : Weather Proof TC Head
- D : Flame Proof IP65
- E : Aluminum Junction Box
- F : Polycarbonate
- G : Cable
- O : Others

## 2 CONNECTION TYPE

### SIZE OF FLANGE

- |                  |                   |              |
|------------------|-------------------|--------------|
| A : Dia75-60PCD  | J : 3" #150       | 5 : 3/8" BSP |
| B : Dia75-65PCD  | K : Dia45-38PCD   | 6 : 1/8" NPT |
| C : Dia100-80PCD | L : Dia58.7-51PCD | 10 : Others  |
| D : 2" #150      | S : Others        |              |
| E : 2 1/2" #150  |                   |              |
| F : 2 1/2" T'E'  |                   |              |
| G : 2" T         |                   |              |
| H : 1 1/2" #150  |                   |              |
| I : 3" T'E'      |                   |              |

### ADAPTER

- 0 : 1/4" BSP
- 1 : 1" BSP
- 2 : 1 1/2" BSP
- 3 : 2" BSP
- 4 : 2" NPT

### PLEASE NOTE :

Flange / Adapter  
Material available in  
variants of **Stainless  
Steel / Mild Steel /  
Aluminium / Brass**

## 3 DIA OD OF STEM WITH MATERIAL

1. Dia 8 of SS304
2. Dia 12.7 of SS304
3. Dia 20 of PP
4. Dia 8 of PP
5. Dia 8 of SS316
6. Dia 12.7 of SS316
7. Dia 8 of Brass
8. Dia 12.7 of Brass
9. Others

## 4 FLOAT TYPE

Type	Material	Float	Dia Stem
S1	SS316	Dia28	Dia8
S2	SS316	Dia30	Dia8
S3	SS316	Dia22	Dia8
S4	SS316	Dia40	Dia12.7
S5	SS316	Dia52	Dia12.7
S6	SS316	Dia89	Dia12.7
P1	PU	Dia22	Dia8
P2	PU	Dia25	Dia8
P3	PU	Dia35	Dia12.7
P4	PP	Dia25	Dia8
P5	PP	Dia50	Dia20

## 5 ELECTRICAL SPECIFICATIONS

1. SDN 102
  2. SDN 104
  3. SDN 202
  4. SDN 204
- Refer table below



### ELECTRICAL SPECIFICATIONS

Model Type	SDN 102	SDN 104	SDN 202	SDN 204
Switching Voltage (Max.)	200 V DC 125 V AC	300 V DC 240 V AC	28 V DC 28 V AC	500 V DC 250 V AC
Switching Current (Max.)	0.5A	3A	0.25A	1.5A
Contact Rating	15VA	100VA	3VA	50VA
Contact Form	SPST	SPST	SPDT	SPDT

## Internal Circuit Diagram Illustrating Reed Switch Contacts & Termination

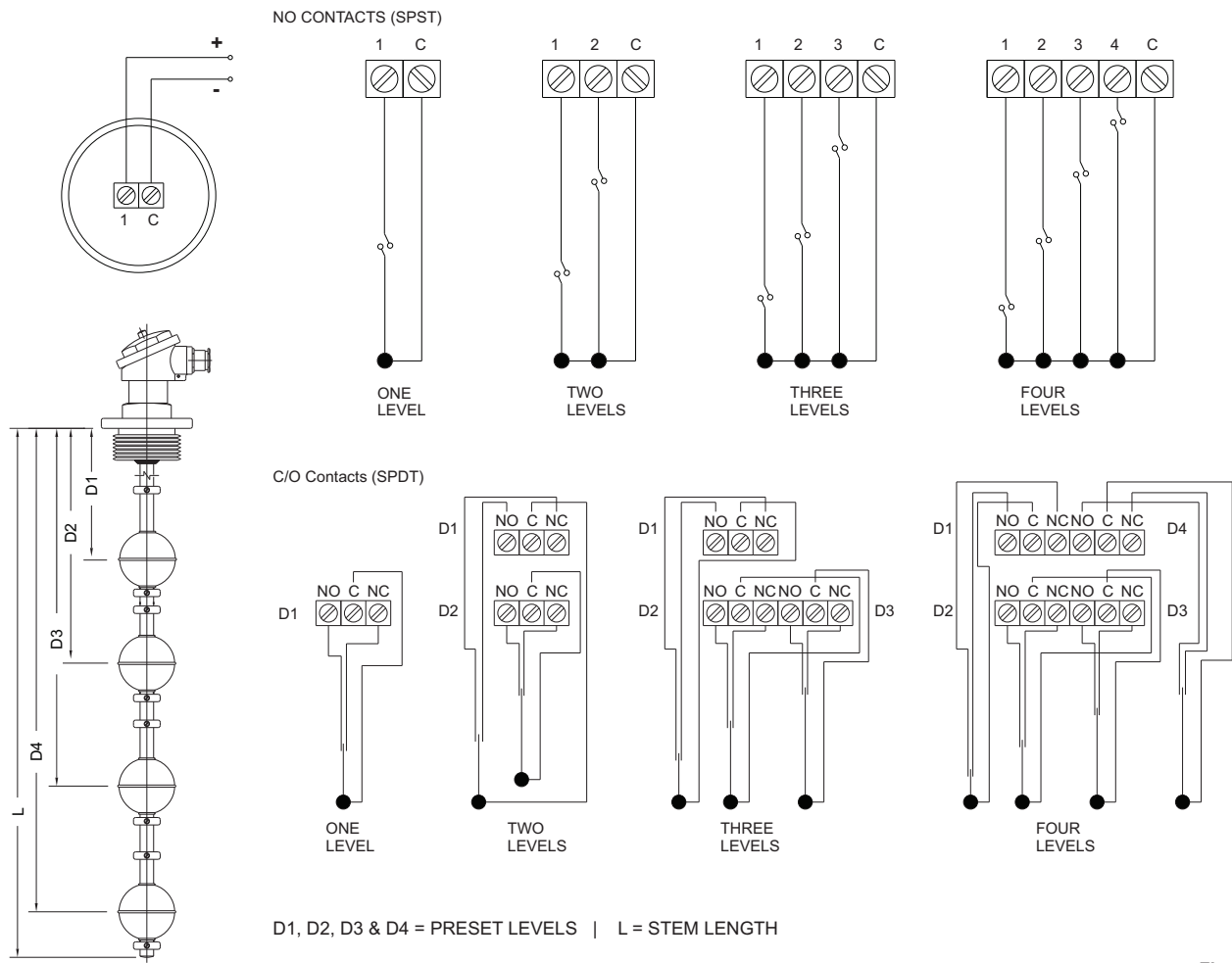

Fig. 06

### APPLICATION

Water / Waste water treatment plants, Cooling towers, Lubrication / Filtration systems, Paint shops, Food / Drug / Pharmaceutical / Chemical & Petrochemical industries.

### ORDERING INFORMATION

Specify part number as per earlier page, guided stem length (L), Preset levels (D1, D2, D3... Etc.), Specific gravity, operating temperature & pressure.

## SHRIDHAN AUTOMATION PVT. LTD.,

#B-54, KSSIDC Industrial Estate, Kumbalagodu,

Mysore Road, Bengaluru - 560074

Ph. : 080 - 28437847 / 28437848 ; Fax : 080 - 28437849

Email : info@shridhan.com ; Website : www.shridhan.com

Note: All dimensions in MM, unless otherwise specified.

Level switches for liquids | Level transmitters for liquids | Level indicators for liquids | Level controllers for liquids

\*Custom built specs. / Options available on request. | **Disclaimer** : We reserve the right to modify the design & specification without prior notice. (CTGE/VFS/6-2009)